

# Performance Optimization of Healthcare Mobile Applications using Embedded System Design and Implementation

Hafez Fouad and Hesham Farouk

Electronics Research Institute, Cairo, Egypt

**Abstract**—An Embedded device is an object that contains a special-purpose computing system. The system, which is completely enclosed by the object, may or may not be able to connect to the Internet. Embedded systems have extensive applications in consumer, commercial, automotive, industrial and healthcare markets. Generally, an embedded device's operating system will only run a single application which helps the device to do its job. The heart of electronics system and also coordinator in communication is embedded system managing biometric data from numerous stationary and on body. This simply means that the device's software does not have a user interface (UI). In such cases, an in-circuit emulator (ICE) is temporarily installed between the embedded device and an external computer to debug or update the software. Because embedded systems have limited computing resources and strict power requirements, writing software for embedded devices is very specialized field that requires knowledge of both hardware components and programming.

This work describes the design of mobile medical system that can be used to monitor the human temperature and heart beat using a stand-alone microcontroller. The system hardware architecture consists of temperature and heart beat sensors, signal conditioning circuits (SCC), single chip microcontroller, LCD display and GSM modem. An embedded software algorithm acquires temperature, heart beat and pressure, processes, transmits displays and stores it in the built-in EPROM of the microcontroller.

**Keywords**—Embedded system, healthcare system, internet of things.

## I. INTRODUCTION

MANY telemedicine mobile applications is now available on the mobile apps stores some of them handle with medical image transfer and others focus on connection between patients and doctors, and another groups of apps present capturing the medical reading. The purpose of applying Mobile applications in healthcare is to minimize the limitations of traditional medical treatment (e.g., small physical storage, security and privacy, and medical errors). Mobile healthcare provides mobile users with convenient helps to access resources (e.g., patient health records) easily and efficiently. Besides, mobile-healthcare offers hospitals and healthcare

organizations a variety of on-demand services on clouds rather than owning stand-alone applications on local servers. There are few schemes of Mobile applications in healthcare. For example, presents five main mobile healthcare applications in the pervasive environment. Comprehensive health monitoring services enable patients to be monitored at anytime and anywhere through broadband wireless communications. Intelligent emergency management system can manage and coordinate the fleet of emergency vehicles effectively and in time when receiving calls from accidents or incidents. Health-ware mobile devices detect pulse rate, blood pressure, and level of alcohol to alert healthcare emergency system. Pervasive access to healthcare information allows patients or healthcare providers to access the current and past medical information [1][2].

Pervasive lifestyle incentive management can be used to pay healthcare expenses and manage other related charges automatically. Similarly, a prototype implementation of mobile healthcare information management system based on Cloud Computing and a mobile client running Android operating system (OS). This prototype presents three services utilizing the Cloud Storage Service to manage patient health records and medical images. Seamless connection to cloud storage allows users to retrieve, modify, and upload medical contents (eg. medical images, patient health records, and biosignals) utilizing web services. Patient health record management system displays the information regarding patients' status, related biosignals, and image contents through application's interface. Image viewing support allows the mobile users to decode the large image files at different resolution levels given different network availability and quality. However, the information to be collected and managed related to personal health is sensitive. Therefore, propose solutions to protect the participant's health information, thereby, increasing the privacy of the services [3].

An embedded device is an object that contains a special-purpose computing system. The system, which is completely enclosed by the object, may or may not be able to connect to the Internet. Embedded systems have extensive applications in consumer, commercial, automotive, industrial and healthcare markets. It is estimated that by 2015, over 15 billion embedded devices will be connected to the internet, a phenomenon commonly referred to as the Internet of Things.

Generally, an embedded device's operating system will only run a single application which helps the device to do its job. Examples of embedded devices include dishwashers, banking ATM machines, routers, point of sale terminals (POS terminals) and cell phones. Devices that can connect to the Internet are called smart or intelligent. If an embedded device cannot connect to the Internet, it is called dumb. Embedded devices in complex manufactured products, such as automobiles, are often headless. This simply means that the device's software does not have a user interface (UI). In such cases, an in-circuit emulator (ICE) is temporarily installed between the embedded device and an external computer to debug or update the software. Because embedded systems have limited computing resources and strict power requirements, writing software for embedded devices is a very specialized field that requires knowledge of both hardware components and programming [4].

## II. PROPOSED HEALTHCARE MOBILE APPLICATION

This paper describes the design and implementation of mobile medical system that can be used to monitor the human temperature, heart beat and blood pressure (BP) using a stand-alone microcontroller. The system hardware architecture consists of temperature and pressure sensors, signal conditioning circuits (SCC), single chip microcontroller, LCD display and GSM modem. An embedded software algorithm acquires temperature, heart beat and pressure, processes, transmits, displays and stores it in the built-in EPROM of the microcontroller. A preset trigger level for the temperature and/or the BP is stored in the EEPROM of microcontroller. Once the desired programmed trigger level of any of the signal is reached, the microcontroller downloads the current value of the temperature and BP to the GSM modem. Then, GSM automatically dials presorted mobile numbers and transmits both parameters as a normal mobile message to a physician, nurse and emergency personal. A complete MYSQL database containing these parameters are collected and stored in a lookup table. This database can be used to track the patient temperature, heart beat and BP history if needed.

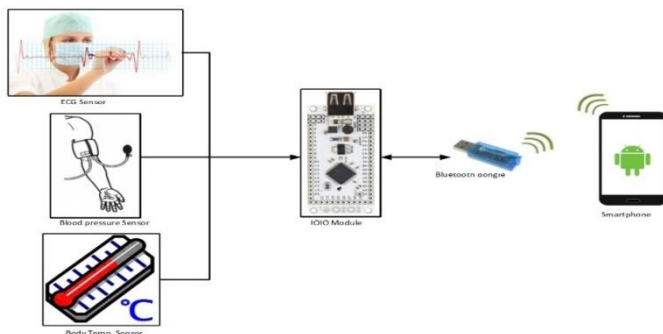

Figure 1 Schematic diagram of sensor network and microcontroller

### A. The proposed Healthcare Mobile Application Phases

1. Development of Telemedicine embedded systems, its operations and administration.

2. Development of Medical electronic contents in different shapes as voice, image and data.
3. Development of Medical Informatics applications and programs, Creation of databases and medical electronic information systems, and its operations and administration.
4. Prototypes manufacturing of parts and components fitted to proposed telemedicine system.

### B. Required Team for the Project

1. Sensor Team: Construct sensors circuits according to provided designs.
2. Transceiver and Microcontroller Team: Research ChipCon transceiver specifications and create a specification that specifies how to connect the Microcontroller to the transceiver.
3. Software Team (Embedded C, Android, PHP web Services).
4. The GUI team will be working to create parallel interface prototype and communication module.

### C. Application flow chart and methodology of Project management

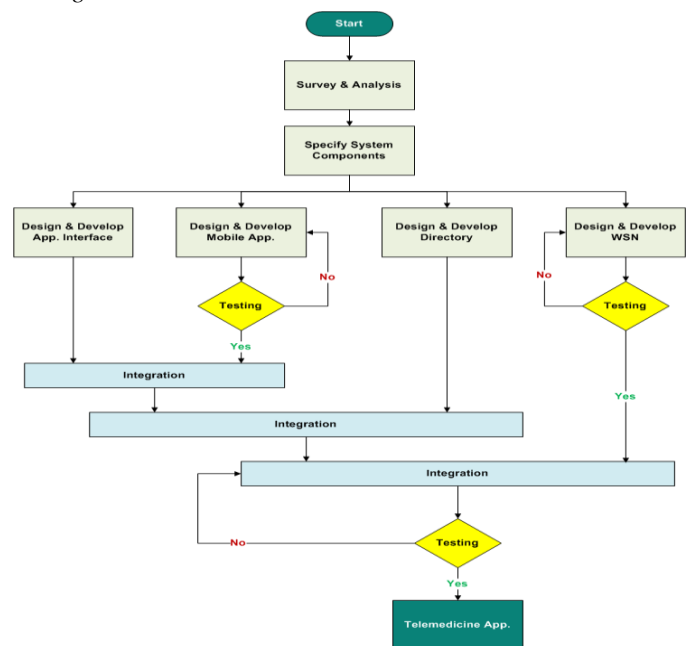

Figure 2 Application flow chart and methodology of project management

### D. The proposed System Architecture

Mobile application collects patient's physiological data through the bio-sensors. The data is aggregated in the sensor network and a summary of the collected data is transmitted to patient's personal computer or cell phone/PDA. These devices forward data to the medical server for analysis. After the data is analyzed, the medical server provides feedback to the patient's personal computer or cell phone/PDA. The patients can take

necessary actions depending on the feedback. The proposed system contains three components. They are

1. Body Sensor Network
2. Patients Personal Server
3. Intelligent Medical Server

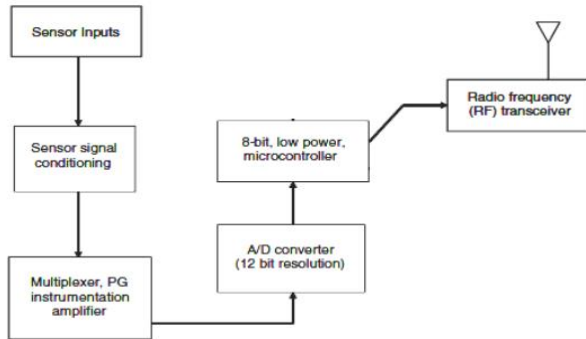

Figure 3 Sensor node hardware design [5]

E. Mobile Embedded System

The heart of electronics system and also coordinator in communication is embedded system managing biometric data from numerous stationary and on body. Next the investigation information about the inquisition parameters are transferred into outer part. The outer part represents the long distance wireless communication within health services.

The flow diagram of the implementation is shown in the Figure 2. The Sensors Network collects patient data and send the data to the Patient profile on the developed mobile application. The mobile app receives the data and processed the data to reduce the transmission of unnecessary data to the Interface Medical service IMS. The mobile app communicates with the Interface Medical service IMS using GPRS. The Interface Medical service IMS contains a Data Mining Unit, a Feedback Unit and a central database. The database contains the entire patients' profile, continuous health data and a large set of rules for data mining operations. The Data Mining unit processes the data and returns the feedbacks and results to the Feedback Unit. The feedback unit then sends the data to the corresponding mobile app. Moreover the patients can login to the medical server using authorized patient-id and password to provide information manually and to view the patient's entire history.

So the prototype implementation was quite smooth. The prototype implementation involves a low cost cell phone and a personal computer. The cell phone acts as the Patient health record PHR whereas the personal computer acts as the Interface Medical service IMS. The cell phone communicates with the personal computer using GPRS which is very cheap and available now with every cell phone. So the setup for the evaluation was really cost effective. We are working on providing RFID based security. In the evaluation we encrypted the data using Advanced Encryption Standard (AES). We used Java Cryptography Extension (JCE) for this purpose, which is a framework for encryption, key generation, and key agreement.

```

LineData data = mchart.getData();
if(data!=null){
    LineDataSet set = data.getDataSetByIndex(0);
    if(set==null){
        set=createSet();
        data.addDataSet(set);
    }
    data.addXValue("");
    data.addEntry(
        new Entry(measuredrate , set
            .getEntryCount(),0);
    //notify chart data have changed
    mchart.notifyDataSetChanged();
    //limit number of visible entries
    mchart.setVisibleXRange(0, 30);
    //scroll to the last entry
    mchart.moveToX(data.getXValCount()-7);
}

private void valuesconversion(final float HR_val,final float TMP_val) {
    float measuredvolt,Rv,measuredtemp,measuredtemp_new=0,tempdiff; // temperature
    float measuredrate; // heart rate variables
    measuredvolt=(float) ((TMP_val*1023)*(3.3/1024)); // map the input digital val
    Rv=(float) ((1000*measuredvolt)/(3.3-measuredvolt)); // get the value of the m
    measuredtemp_new=(float) ((1/(0.0002545*Math.Log(Rv/2252)+0.0033535))-273.15);
    tempdiff=(measuredtemp_new-measuredtemp_old);
    measuredtemp=measuredtemp_new;
    if(tempdiff>0.2){
        measuredtemp=measuredtemp_new;
    }else{
        measuredtemp=measuredtemp_old;
    }
    measuredtemp_old=measuredtemp;
}
    
```

Figure 4 Code programming of embedded healthcare system

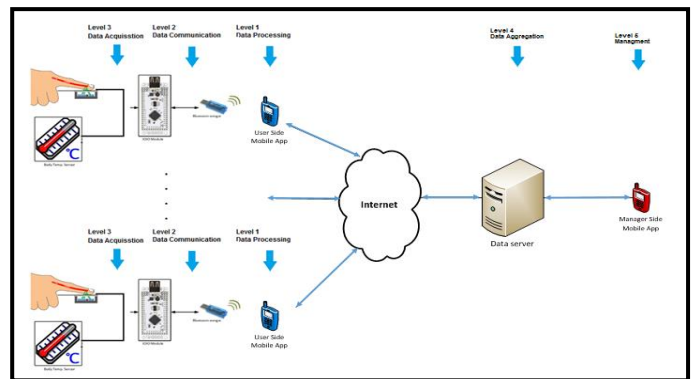

Figure 5 Global system architecture with 4 levels

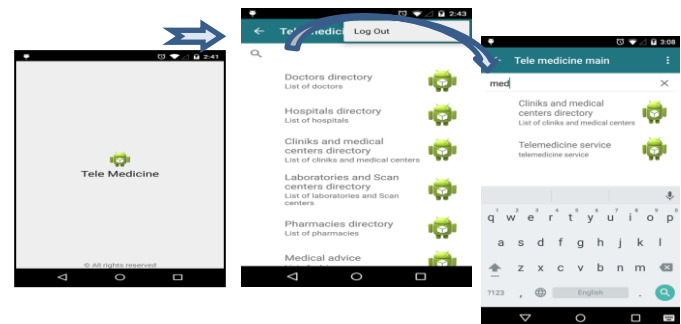
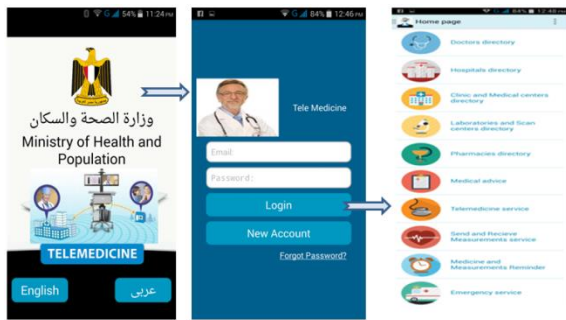
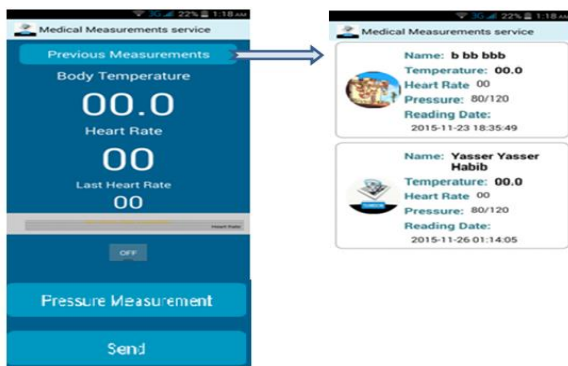

Figure 6 Proposed telemedicine mobile applications screen shot: main screens

Some screenshots of these activities are shown in the **Figures 6 and 7**. They show the screen shots in Interface Medical service IMS for patients profile information and manual health data submission.



**Figure 7** Proposed telemedicine mobile applications screen shot: main services

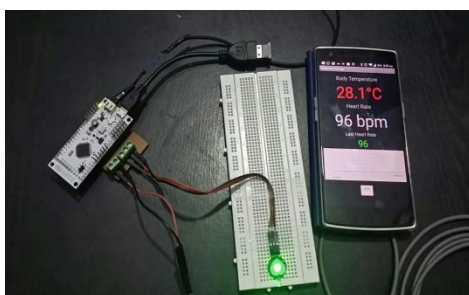

**Figure 8** Proposed telemedicine mobile applications screen shot: sensor reading

**Figure 8** shows show the automated health data collection of mobile app and display of feedbacks provided by IMS based on the collected data and also shows patient's entire medical history with the feedbacks and results stored in the IMS's central database.

The interfaces of mobile app and IMS are user friendly. Any people with little or no technical knowledge can use it without any difficulties. The communication architecture is very simple and flexible as we claimed. There is no complexity in communication between the components of Interface Medical service IMS.

*F. Implementation of Mobile application for Telemedicine system*



**Figure 9** Real photo for the system components

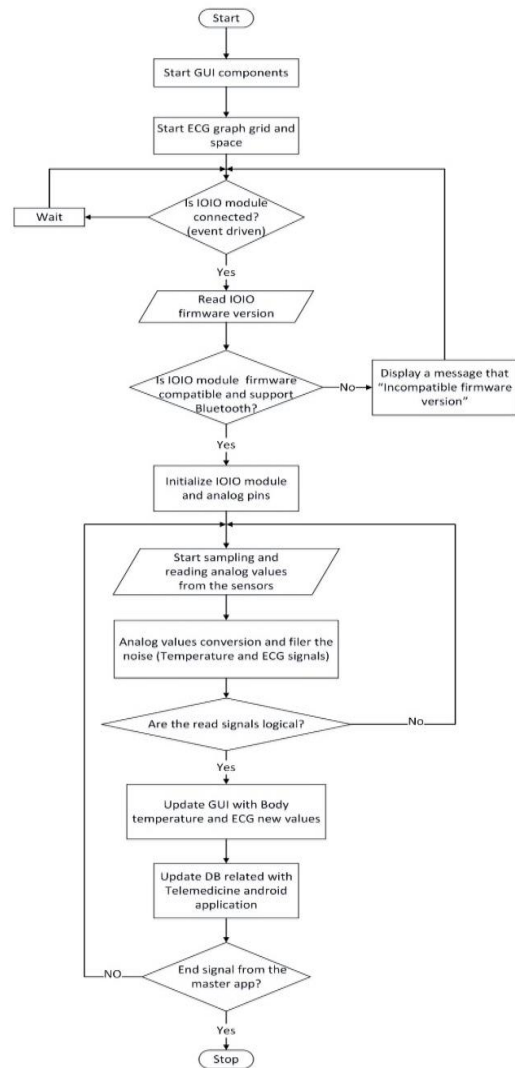

**Figure 10** Proposed mobile application flow chart

III. CONCLUSION AND FUTURE WORKS

The whole system of mobile health care using biosensor network places forward some future works such as finding the most effective mechanism for ensuring security in biosensors considering the severe restrictions of memory and energy, representing the collected data in the most informative manner with minimal storage and user interaction, modeling of data so that the system will not represent all the data but only relevant information thus saving memory. These are the generic works that can be done in future in the sector of mobile health care. For IMHMS our vision is much wider. We think of a system where the patients need not to do any actions at all. With the advancement of sensor technologies it is not far enough when the bio-sensors itself can take necessary actions. A patient needed glucose does not need to take it manually rather the bio-sensors can push the glucose to the patient's body depending on the feedback from the IMS. It seems to be impossible to achieve by everybody.

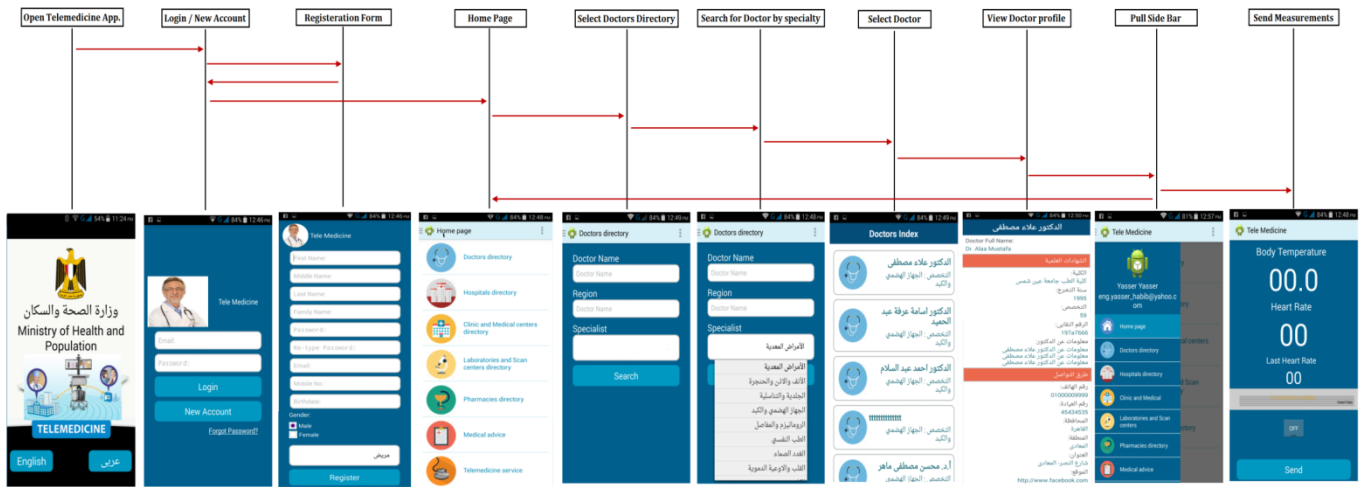

Figure 11 Scenario 1: Patient



Figure 12 Scenario 2: Doctor

But nothing is impossible. Today we imagine of something and see that it is implemented in the near future. But if we stop imagine and thinking then how impossible can be made possible? This paper demonstrates an intelligent system for mobile health monitoring. Smart sensors offer the promise of significant advances in medical treatment. Networking multiple smart sensors into an application-specific solution to combat disease is a promising approach, which will require research with a different perspective to resolve an array of novel and challenging problems. As wireless networks of sensors are developed for biomedical applications, the knowledge gained from these implementations should be used to facilitate the development of sensor networks for new applications. Expeditious development of implanted smart sensors to remedy medical problems presents clear benefits to individuals as well as society as a whole. There is the obvious benefit to persons with debilitating diseases and their families as these patients gain an enhanced quality of life. Biomedical implants that monitor for cancer will help recovering patients maintain their health. Not only will these individuals personally benefit from their improved health and well-being, but society will also

benefit from their increased productivity and societal contributions. Once the technology is refined, medical costs for correcting chronic medical conditions will be reduced. As the world population increases, the demand for such system will only increase. We are implementing the IMHMS to help the individuals as well as the whole humanity. Our goals will be fulfilled if the IMHMS can help a single individual by monitoring his or her health and cautions him to take necessary actions against any upcoming serious diseases.

REFERENCES

- [1] Hafez Fouad, " Embedded System Design of Remote Healthcare Monitoring Center using Web-Technology ", International Journal of Robotics and Mechatronics IJRM, Vol.2, Issue 2, 2015.
- [2] Hafez Fouad, Hesham Farouk, " Design and Implementation of Wireless Sensors Network and Cloud Based Telemedicine System for Rural Clinics and Health Centers", International Journal of Scientific & Engineering Research (IJSER), Vol. 6, Issue 2, February 2015. [CrossRef](#)
- [3] Itelemedicine, [VIEW](#)
- [4] Hafez Fouad, "Continuous Health-monitoring for early Detection of Patient by Web Telemedicine System", International Conference on Circuits, Systems and Signal Processing, Saint Petersburg State

- Politechnical University, Russia, Sep, 23-25, 2014. ISBN: 978-1-61804-249-1.
- [5] Hafez Fouad, " Patient-oriented Web Telemedicine system For Health Monitoring ", Journal of Communication and Computer, CA 91745, USA, Vol.11, Issue 2, pp-168-178, Feb., 2014.
  - [6] U.S. Department of Health and Human Services and Services Administration Bureau of Health Professionals (2000). The Pharmacist Workforce: A Study of the Supply and Demand for Pharmacists.
  - [7] Sarasohn-Kahn J (2011). The Connected Patient: Charting the Vital Signs of Remote Health Monitoring, California Health Care Foundation.
  - [8] Edwards J, et al (2009). Hype Cycle for Telemedicine, Gartner Industry Research. Publication G00169011.
  - [9] Bergmo TS (2010). Economic Evaluation in Telemedicine – Still Room for Improvement, J Telemed Telecare 16.5 (2010): 229-31. [CrossRef](#)
  - [10] Young LB, et al (2011). Impact of Telemedicine Intensive Care Unit Coverage on Patient Outcomes: A Systematic Review and Meta-analysis, Arch Intern Med 171.6: 498-506. [CrossRef](#)
  - [11] Sagepub [VIEW](#)
  - [12] Digital Stethoscope, [VIEW](#)
  - [13] [www.ubicc.org](http://www.ubicc.org)
  - [14] AMD Telemedicine, [VIEW](#)